

Hardware Documentation

*SolderCoreBBHD – Battery Adapter
ADP-SC8ULP-BAT
for HW Revision 1.20*

preliminary

Version 002
(2024-06-11)

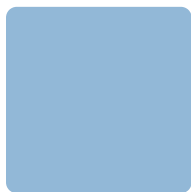

**Elektronik
Systeme**

© F&S Elektronik Systeme GmbH

Untere Waldplätze 23

D-70569 Stuttgart

Phone: +49(0)711-123722-0

Fax: +49(0)711-123722-99

About This Document

This document describes how to use the [SolderCoreBBHD – Battery Adapter](#) (further named as battery adapter) with mechanical and electrical information. The latest version of this document can be found at: <http://www.fs-net.de>.

This document is written for the variants of the battery adapter, listed in the table below.

Related Boards
SolderCoreBBHD – Battery Adapter Rev.1.20

ESD Requirements



All F&S hardware products are ESD (electrostatic sensitive devices). All products are handled and packaged according to ESD guidelines. Please do not handle or store ESD-sensitive material in ESD-unsafe environments. Negligent handling will harm the product and warranty claims become void.

History

Date	V	Platform	A,M,R	Chapter	Description	Au
20.12.23	001	-	-	All	Initial Version	SM
18.06.24	002	-	A,M,R	All	New HW Revision	SM

V	Version
A, M, R	Added, Modified, Removed
Au	Author

Table of Contents

About This Document	2
ESD Requirements	2
History	2
Table of Contents	3
1 Additional Documentation	4
2 Overview	4
3 Detailed Description	5
3.1 Connection	5
3.1.1 Baseboard	5
3.1.2 Battery	5
3.2 Functionality	6
3.2.1 Charging Inputs	6
3.2.2 Status LEDs.....	7
3.3 USB	7
3.3.1 ID connection.....	7
3.3.2 Adapter detection	8
4 Electrical Characteristics	9
4.1 Absolute Maximum Ratings	9
4.2 Recommended Operating Conditions	9
5 ESD and EMI Implementation	10
6 Second source rules	10
7 Storage conditions	10
8 ROHS and REACH statement	10
9 Packaging	11
10 Matrix Code Sticker	11
11 Appendix	12
Important Notice	12
Warranty Terms.....	13
12 Content	14



1 Additional Documentation

Due to the fact, that the battery adapter is designed to be directly connected to the SolderCoreBBHD (further called baseboard), it is recommended to read the baseboard documentation previously.

2 Overview

The battery adapter gives the possibility to fully supply the baseboard over a Li Ion battery cell.

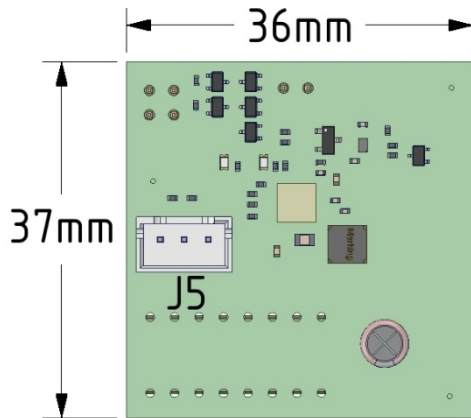

Figure 1: Top side

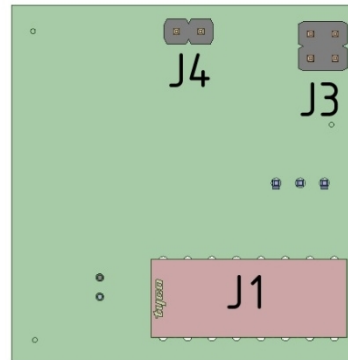
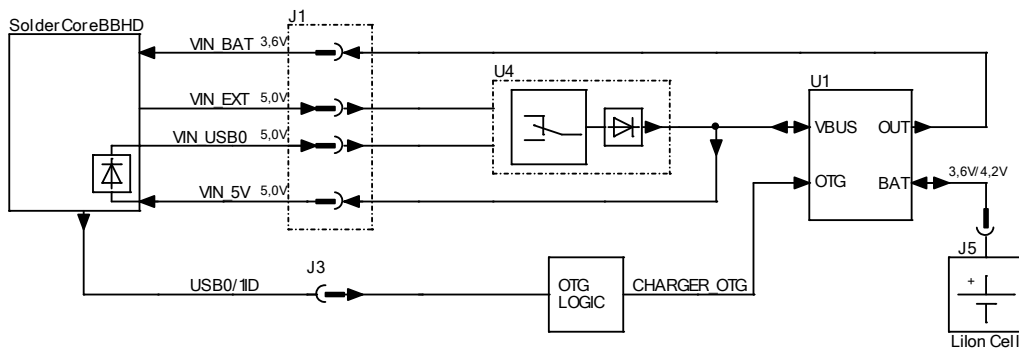

Figure 2: Bottom side



U1 States	VBUS	OUT	BAT
Battery charging (OTG: HIGH/LOW, ext. source)	5V	3,6V	4,2V
Battery supplies OUT only (OTG: LOW, no ext. source)	0V	3,6V	3,6V
Battery supplies OUT & VBUS (OTG: HIGH, no ext. source)	5V	3,6V	3,6V

Figure 3: Block diagram

Ref.	Description	I/O	No. of Pins	Connector Type
J1	Board-to-board connection	PWR	16	Socket 90° (2.54 mm)
J3	USB ID in	I/O	4	Pin Header (2.54 mm)
J4	USB data in	I/O	2	Pin Header (2.54 mm)
J5	Battery	PWR	3	JST-XH 2.50mm

Table 1: Connector overview

3 Detailed Description

3.1 Connection

3.1.1 Baseboard

The battery adapter is mounted on baseboard connector J28, as shown in figure 2.

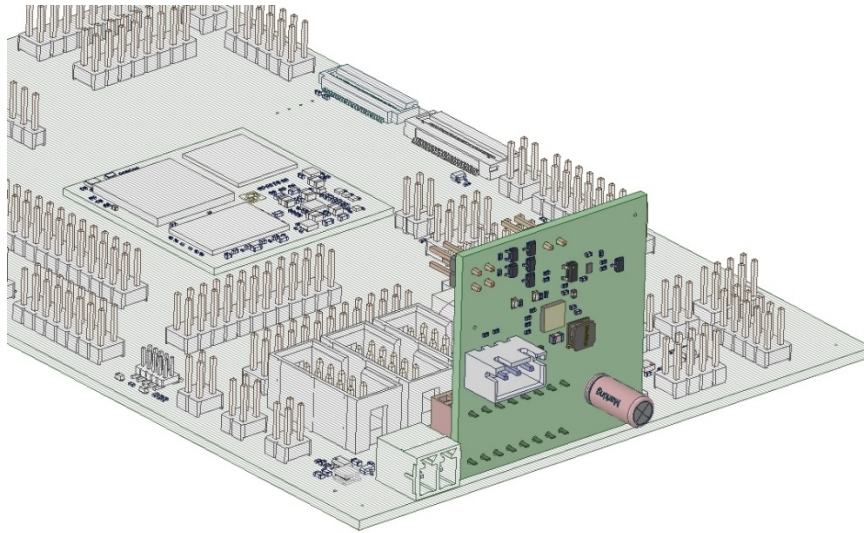

Figure 4: Battery adapter mounting position on baseboard

3.1.2 Battery

J5 is the connection for a Lilon Battery. The charging current is limited to 1A. **It is highly recommended to use a battery with a 10kΩ NTC and its own protection circuit, to prevent harm!**

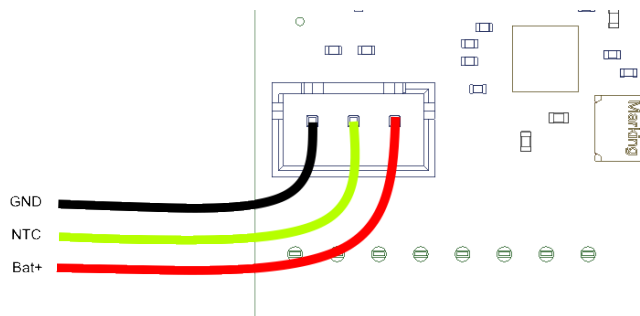

Figure 5: Battery wiring

Color	Signal	Description
black		GND
yellow	NTC	10kΩ Thermistor
red	Bat+	Battery cathode

Table 2: Battery wiring

3.2 Functionality

The charging functionality is handled by the BQ25616.

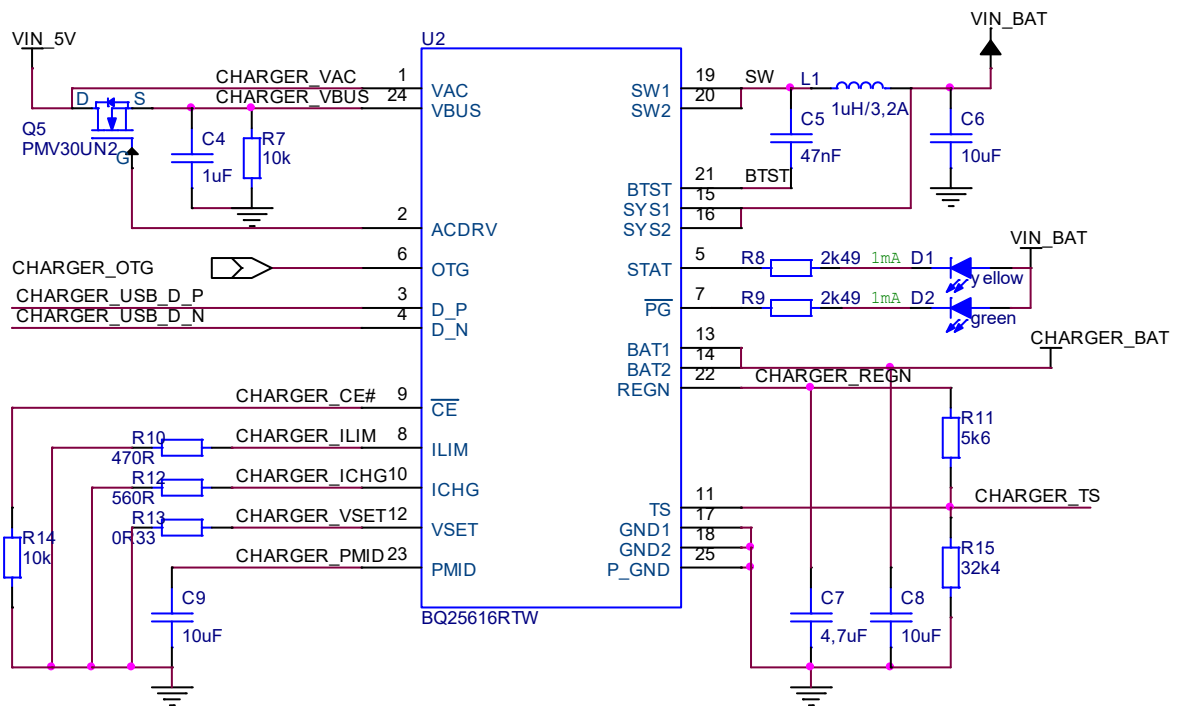

Figure 6: Schematic charging IC

3.2.1 Charging Inputs

Charging is possible via external input or USB0 of the baseboard. The external input has priority. A charging adapter with at least 1A output should be used.

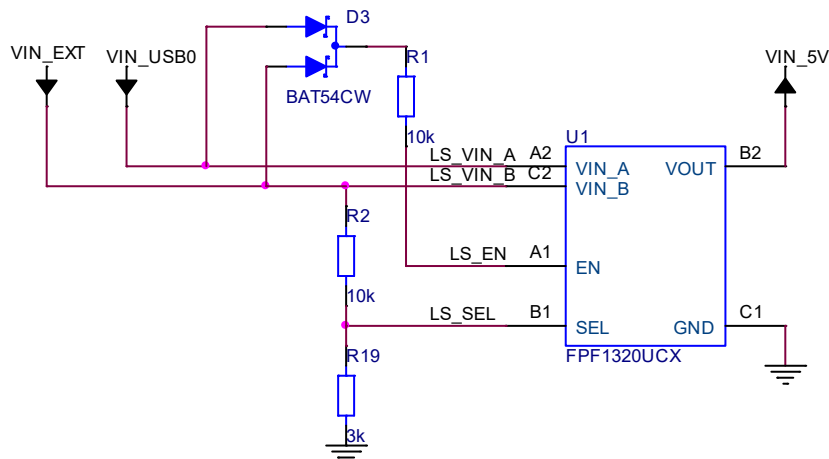

Figure 7: Schematic input selection

3.2.2 Status LEDs

The LEDs on the battery adapter show the charging and input voltage status.

Ref.	Signal	Color	Description
D1	Status	yellow	On: charging Off: charging done/sleep Blink (1Hz): error
D2	Power Good	green	On: input voltage good, Off: bad input voltage

Table 3: LED states

3.3 USB

3.3.1 ID connection

To charge the battery over USB0, the ID signals and VIN_BAT (as pull up reference) should be connected to the adapter.

If you don't want to charge over USB you must bridge the USBx_ID pins with VIN_BAT on J3.

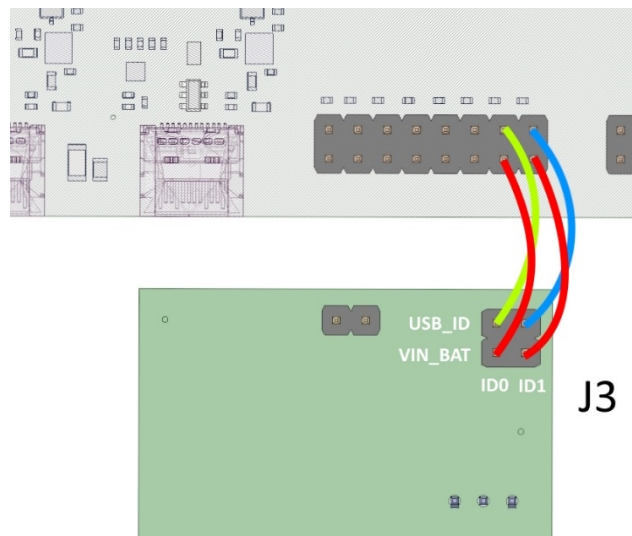

Figure 8: USB ID wiring

Pin	Signal Name	I/O	Voltage	Description	Wire Color
1	USB0_ID	I/O	3.3V	USB0 ID signal, high active	Blue
2	USB1_ID	I/O	3.3V	USB0 ID signal, high active	Yellow
3	VIN_BAT				Red
4					

Table 4: Connector J3

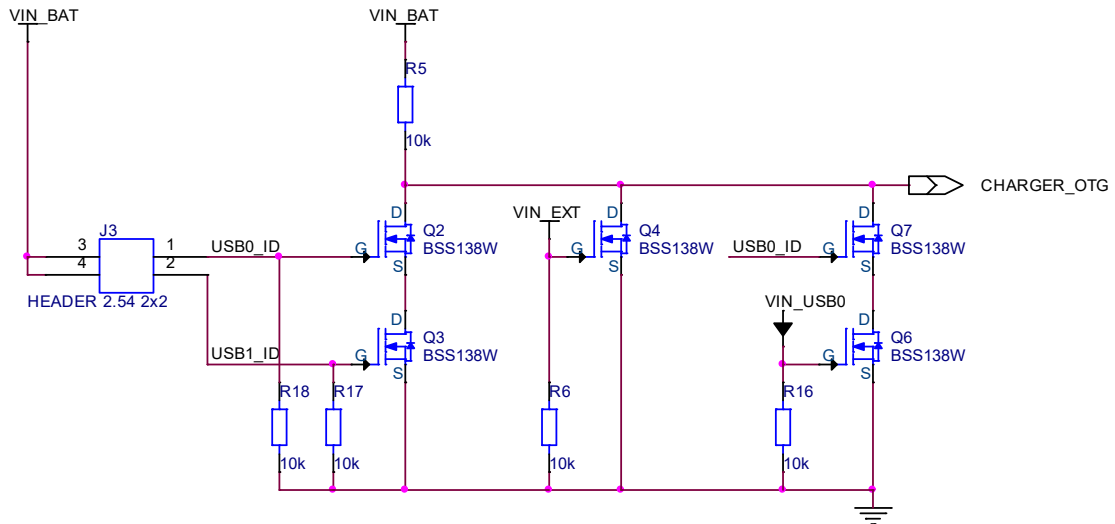
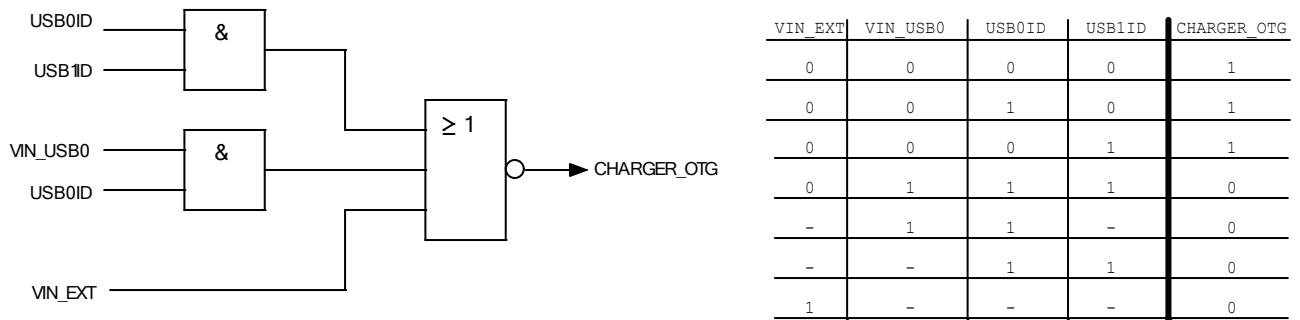

Figure 9: Schematic ID detection



note to USB0/1 ID:
 LOW: UFP(device)
 HIGH: DFP(host) or USB not connected

Figure 10: Logic of ID detection

3.3.2 Adapter detection

The charging IC supports the communication with the USB charging adapter.

Note: As this functionality isn't implemented on the baseboard, the signals are routed to J4 for development purposes only.

Pin	Signal Name	I/O	Description
1	D-	I/O	USB 2.0 differential pair, negative -
2	D+	I/O	USB 2.0 differential pair, positive +

Table 5: Connector J4

4 Electrical Characteristics

As the battery adapter is an expansion of the SolderCoreBBHD, please also see the SolderCoreBBHD documentation for the electrical characteristics.

4.1 Absolute Maximum Ratings

Parameter.	Description	Min	Max	Unit
Bat+	Battery voltage	-0.30	7.00	V
D-, D+	USB data signals	-0.30	7.00	V

Table 6: Absolute Maximum Ratings

4.2 Recommended Operating Conditions

Parameter.	Description	Min	Typ.	Max	Unit
Bat+	Battery charging voltage		4.20		V
	Battery voltage			4.35	V

Table 7: Recommended Operation Conditions

5 ESD and EMI Implementation

The connectors do not have any ESD protection. We highly recommend using the adapter board with wires as short as possible.

A helpful guide is available from TI; just search for slva680 at ti.com.

6 Second source rules

F&S qualifies their second sources for parts autonomously, if this does not touch the technical characteristics of the product. This is necessary to guarantee delivery times and product life. A setup of release samples with released second sources is not possible.

F&S does not use broker components without the consent of the customer.

7 Storage conditions

Maximum storage on room temperature with non-condensing humidity:	6 months
Maximum storage on controlled conditions 25 ±5 °C, max. 60% humidity:	12 months

For longer storage, we recommend vacuum dry packs.

8 ROHS and REACH statement

All F&S designs are created from lead-free components and are completely ROHS compliant.

The products we supply do not contain any substance on the latest candidate list published by the European Chemicals Agency according to Article 59(1,10) of Regulation (EC) 1907/2006 (REACH) in a concentration above 0.1 mass %.

Consequently, the obligations in No. 1 and 2 paragraphs in Annex are not relevant here.

Please understand that F&S is not performing any chemical analysis on its products to testify REACH compliance and is therefore not able to fill out any detailed inquiry forms.

9 Packaging

All F&S ESD-sensitive products will be shipped either in trays or in bags.

10 Matrix Code Sticker

All F&S hardware will ship with a matrix code sticker including the serial number. Enter your serial number here <https://www.fs-net.de/en/support/serial-number-info-and-rma/> to get information on shipping date and type of board.



Figure 11: Matrix Code Sticker

11 Appendix

Important Notice

The information in this publication has been carefully checked and is believed to be entirely accurate at the time of publication. F&S Elektronik Systeme (“F&S”) assumes no responsibility, however, for possible errors or omissions, or for any consequences resulting from the use of the information contained in this documentation.

F&S reserves the right to make changes in its products or product specifications or product documentation with the intent to improve function or design at any time and without notice and is not required to update this documentation to reflect such changes.

F&S makes no warranty or guarantee regarding the suitability of its products for any particular purpose, nor does F&S assume any liability arising out of the documentation or use of any product and specifically disclaims any and all liability, including without limitation any consequential or incidental damages.

Specific testing of all parameters of each device is not necessarily performed unless required by law or regulation.

Products are not designed, intended, or authorized for use as components in systems intended for applications intended to support or sustain life, or for any other application in which the failure of the product from F&S could create a situation where personal injury or death may occur. Should the Buyer purchase or use a F&S product for any such unintended or unauthorized application, the Buyer shall indemnify and hold F&S and its officers, employees, subsidiaries, affiliates, and distributors harmless against all claims, costs, damages, expenses, and reasonable attorney fees arising out of, either directly or indirectly, any claim of personal injury or death that may be associated with such unintended or unauthorized use, even if such claim alleges that F&S was negligent regarding the design or manufacture of said product.

Specifications are subject to change without notice.

Warranty Terms

Hardware Warranties

F&S guarantees hardware products against defects in workmanship and material for a period of one (1) year from the date of shipment. Your sole remedy and F&S's sole liability shall be for F&S, at its sole discretion, to either repair or replace the defective hardware product at no charge or to refund the purchase price. Shipment costs in both directions are the responsibility of the customer. This warranty is void if the hardware product has been altered or damaged by accident, misuse or abuse.

Software Warranties

Software is provided "AS IS". F&S makes no warranties, either express or implied, with regard to the software object code or software source code either or with respect to any third party materials or intellectual property obtained from third parties. F&S makes no warranty that the software is useable or fit for any particular purpose. This warranty replaces all other warranties written or unwritten. F&S expressly disclaims any such warranties. In no case shall F&S be liable for any consequential damages.

Disclaimer of Warranty

THIS WARRANTY IS MADE IN PLACE OF ANY OTHER WARRANTY, WHETHER EXPRESSED, OR IMPLIED, OF MERCHANTABILITY, FITNESS FOR A SPECIFIC PURPOSE, NON-INFRINGEMENT OR THEIR EQUIVALENTS UNDER THE LAWS OF ANY JURISDICTION, EXCEPT THE WARRANTY EXPRESSLY STATED HEREIN. THE REMEDIES SET FORTH HEREIN SHALL BE THE SOLE AND EXCLUSIVE REMEDIES OF ANY PURCHASER WITH RESPECT TO ANY DEFECTIVE PRODUCT.

Limitation on Liability

UNDER NO CIRCUMSTANCES SHALL F&S BE LIABLE FOR ANY LOSS, DAMAGE OR EXPENSE SUFFERED OR INCURRED WITH RESPECT TO ANY DEFECTIVE PRODUCT. IN NO EVENT SHALL F&S BE LIABLE FOR ANY INCIDENTAL OR CONSEQUENTIAL DAMAGES THAT YOU MAY SUFFER DIRECTLY OR INDIRECTLY FROM USE OF ANY PRODUCT. BY ORDERING THE PRODUCT, THE CUSTOMER APPROVES THAT THE F&S PRODUCT, HARDWARE AND SOFTWARE, WAS THOROUGHLY TESTED AND HAS MET THE CUSTOMER'S REQUIREMENTS AND SPECIFICATIONS



12 Content

Table 1: Connector overview	4
Table 2: Battery wiring	5
Table 3: LED states	7
Table 4: Connector J3	7
Table 5: Connector J4	8
Table 6: Absolute Maximum Ratings	9
Table 7: Recommended Operation Conditions.....	9
Figure 1: Top side.....	4
Figure 2: Bottom side.....	4
Figure 3: Block diagram.....	4
Figure 4: Battery adapter mounting position on baseboard.....	5
Figure 5: Battery wiring.....	5
Figure 6: Schematic charging IC	6
Figure 7: Schematic input selection.....	6
Figure 8: USB ID wiring	7
Figure 9: Schematic ID detection.....	8
Figure 10: Logic of ID detection.....	8
Figure 11: Matrix Code Sticker	11