

Hardware Documentation

armStone™ A9r2

armStone™ A9r4

Version 107
(2025-01-13)



**Elektronik
Systeme**

© F&S Elektronik Systeme GmbH

Untere Waldplätze 23

D-70569 Stuttgart

Phone: +49(0)711-123722-0

Fax: +49(0)711-123722-99

About This Document

This document describes how to use the [arnStone™ A9R2](#) board with mechanical and electrical information. The latest version of this document can be found at:

<http://www.fs-net.de>.

ESD Requirements



All F&S hardware products are ESD (electrostatic sensitive devices). All products are handled and packaged according to ESD guidelines. Please do not handle or store ESD-sensitive material in ESD-unsafe environments. Negligent handling will harm the product and warranty claims become void.

History

Date	V	Platform	A,M,R	Chapter	Description	Au
2015-09-28	0.1	ASA9R2	A	*	First Preliminary version	DB
2015-11-03	0.1	ASA9R2	M	3	Changed Block Diagram Image	JG
2016-05-24	0.2	ASA9R2	A		Added Camera Interface	DB
2016-06-07	0.3	ASA9R2	A		Add operating humidity and storage conditions	KW
2016-12-01	0.5	ASA9R2	M		Removed I2C from feature connector	DB
2017-04-27	0.6	ASA9R2	A		Add max. power at LVDS connector	DB
2017-10-23	0.7	ASA9R2	A		Add second source rule Add link for Letter of conformity for WLAN option	KW
2017-11-13	080	ASA9R2	A		ESD warning	HF
2018-09-18	080	ASA9R2	A		Extend thermal specification	JG
2020-07-17	090	ASA9R2	M, A		Change to new F&S Layout	MW
2021-10-14	105	ASA9R2	M	4.6	Reset Signal on LVDS Connector	MW
2023-02-10	106		A		Add armStoneA9r4	DB
2025-01-13	107	*	M	5.13	Feature Connector Pin 66 changed to GND	ZU

V	Version
A,M,R	Added, Modified, Removed
Au	Author

Table of Contents

About This Document	2
ESD Requirements	2
History	2
Table of Contents	3
1 Block diagram	5
2 Mechanical Dimension	6
3 Difference between r2 and r4	7
4 Technical Data armStoneA9r2/r4	7
4.1 Technical Data.....	7
4.2 Thermal Specification	8
5 Interfaces	9
5.1 Gbit Ethernet LAN	9
5.2 USB Host Connector	9
5.3 USB Device Connector.....	10
5.4 Digital Monitor Connector	10
5.5 microSD Connector	10
5.6 LVDS Connector.....	10
5.7 Backlight control connector	11
5.7.1 Solution with a single cable with 3 connectors	11
5.7.2 Solution with 2 cable with 2 connectors each	12
5.8 I2C connector for touch module	13
5.9 Mini PCI Express	13
5.10 CAN	13
5.11 Camera	14
5.12 WLAN (r2 only)	14
5.13 66 Pin Feature Connector	15
5.13.1 Audio	17
5.13.2 RS232 COM port	18
5.13.3 TTL COM port.....	18
5.13.4 SPI.....	19
5.13.5 ADC In	19
5.13.6 PWM out.....	19
5.13.7 Matrix keyboard	19
5.13.8 GPIOs	19
5.13.9 MISC signals, power.....	20
5.13.10 CAN Bus.....	20



5.14	Power connector.....	21
6	Electrical characteristic	22
6.1	Absolute maximum ratings	22
6.2	DC Electrical Characteristics	22
7	Thermal Specification	23
8	ADP-NT24V2	24
9	Review service	24
10	Second source rules	24
11	Power consumption and cooling	24
12	Storage conditions	25
13	ROHS and REACH statement	25
14	Packaging	26
15	Matrix Code Sticker	26
16	Appendix	27
	Important Notice	27
	Warranty Terms.....	28
17	Content	29

1 Block diagram

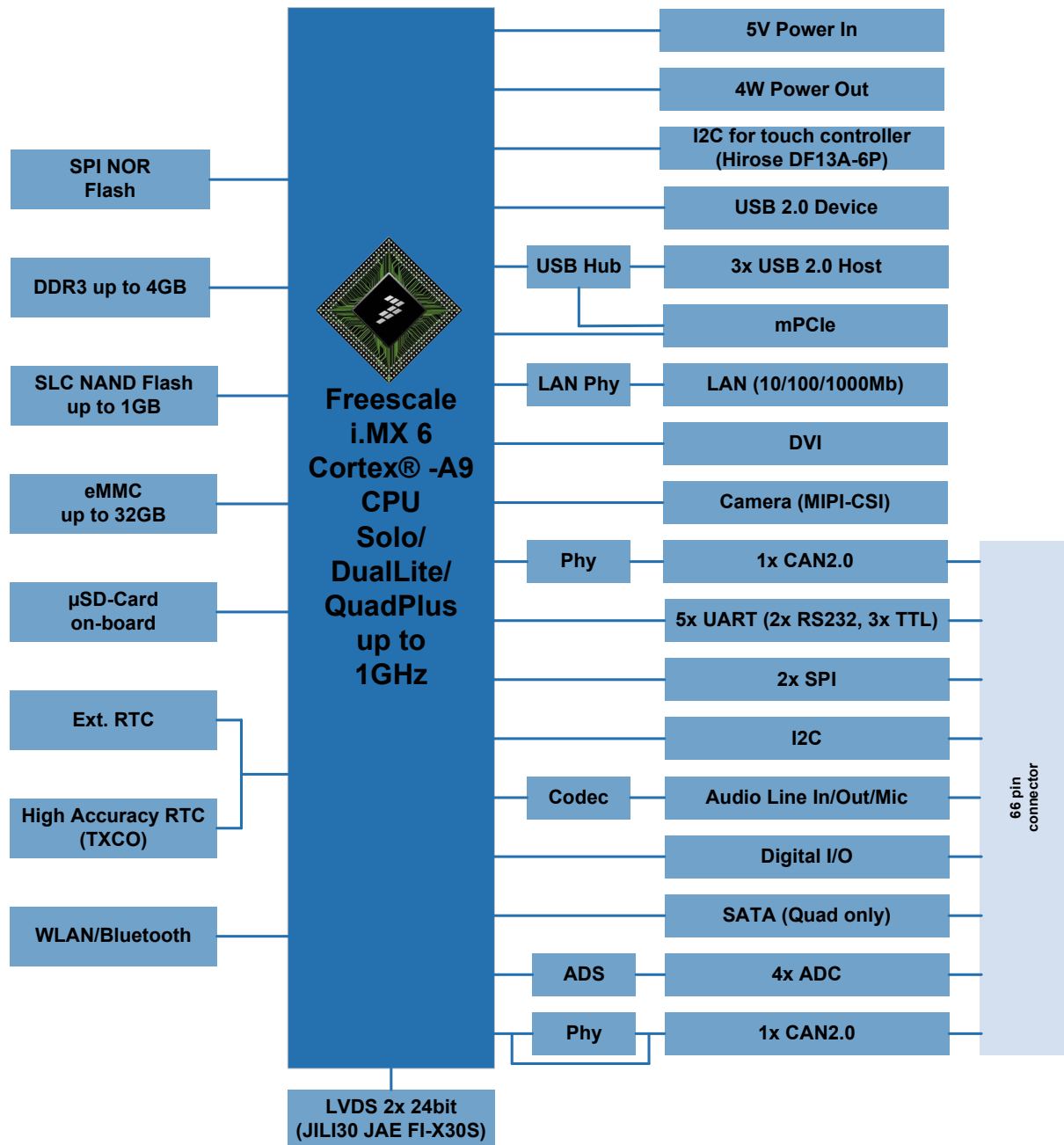

Figure 1: Block Diagram

2 Mechanical Dimension

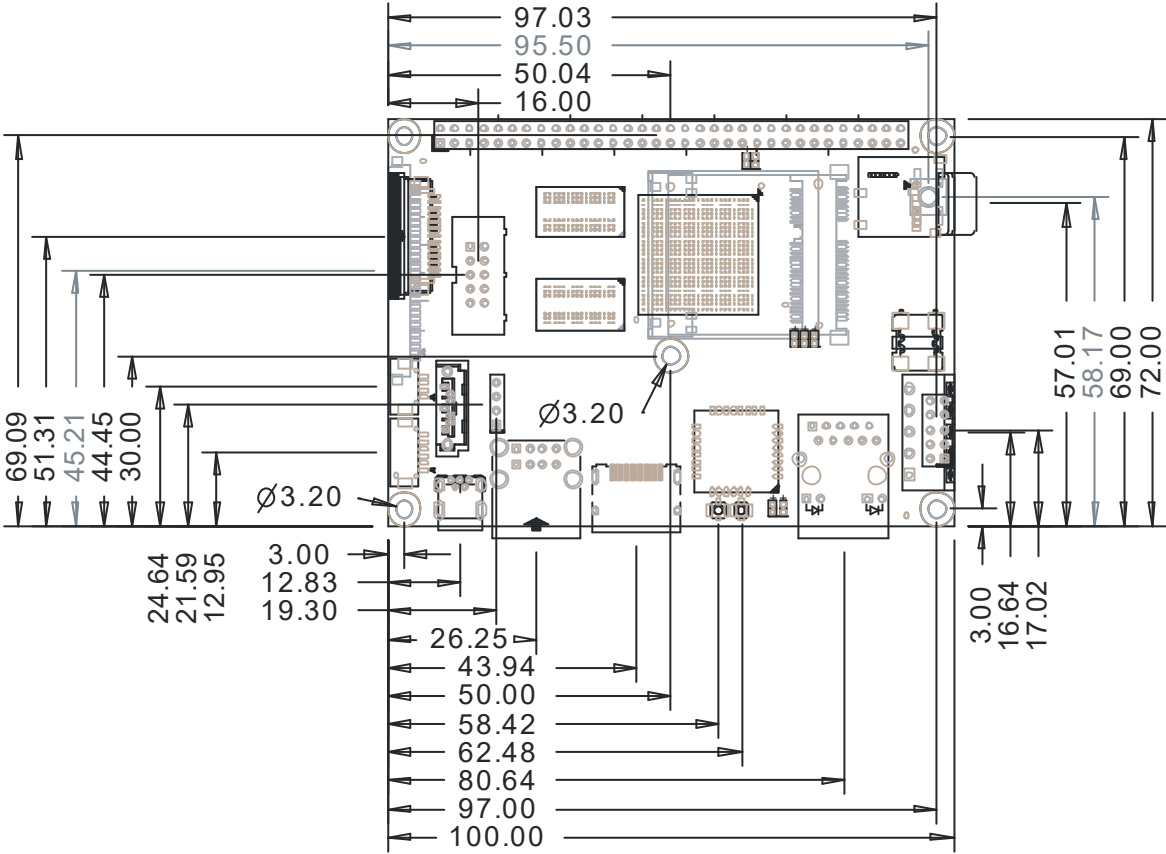

Figure 2: Mechanical Dimension

Dimensions	Description
Size	472mm x 100mm (picoITX)
PCB Thickness	1.6mm ± 0.1mm
Height of the parts on the top side	Max. 17mm
Height of the parts on the bottom side	Max. 7mm

Table 1: Mechanical Dimensions

3D Step model available, please contact support@fs-net.de

3 Difference between r2 and r4

armStoneA9r2 has Qualcomm EthernetPhy and WLAN, armStoneA9r4 has Realtek Ethernet-Phy and no WLAN

4 Technical Data armStoneA9r2/r4

4.1 Technical Data

Power supply:	5V DC \pm 5
Interfaces:	1x Ethernet 10/100/1000Mbit 4x USB 2.0 Host 1x USB 2.0 Device 1x digital monitor 1x microSD card connector push-push 1x mPCIe Half Mini Card 1x SATA (only with quad core CPU) 1x I2C for touch module 1x stereo Audio LineIn, LineOut, Mic 2x serial port RS232 3x serial port TTL 4x ADC In (10 bit, 500kSPS, optional on custom version) 3x PWM out 2x SPI 2x CAN 1x MIPI-CSI camera, optional 17x GPIO 1x WLAN (armStoneA9r2 only)
LCD-interfaces:	1x 2x 24bit LVDS JILI30
Memory:	1 GByte DDR3 DRAM (up to 4GB) 256 MByte NAND Flash (to 1 GB) Up to 32GB eMMC (optional)
CPU:	Freescale i.MX6 CPU CortexA9 Single-/Dual-/Quad core up to 1.2GHz
Operating temperature:	0°C...+70°C (optional -20...+85°C)

4.2 Thermal Specification

	Min	Typ	Max	Unit
Operating temperature	0		+70 ¹	°C
Operating temperature ("I") ²	-20		+85 ¹	°C
Junction temperature i.MX6	-20		+105	°C
Junction temperature i.MX6 ("I") ²	-20		+105	°C
Junction to Top of i.MX6 (Psi-JT) ³		2		°C/W

Table 2: Thermal Specification

¹ Depending on cooling solution. See also:

² Optional

³ Temperature difference between package top and the junction temperature per JEDEC JESD51-2.

5 Interfaces

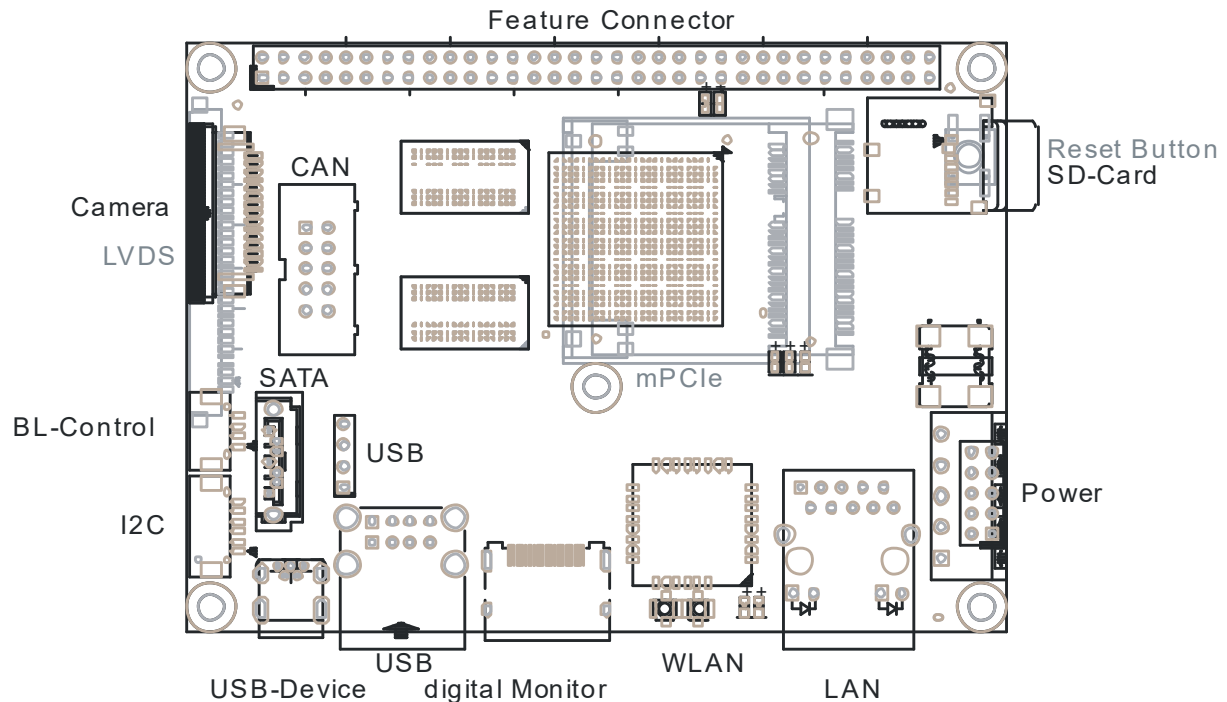

Figure 3: Connector Layout

5.1 Gbit Ethernet LAN

The LAN1 connector does support 10, 100 and 1000 Mbit LAN.

5.2 USB Host Connector

The double USB Host connector does support USB2.0 connection with High speed up to 480Mbit/s and also full and low speed devices.

The on-board pin connector for internal USB does have the following pin out.

Pin	Signal	I/O	Voltage	Remarks
1	+5V	PWR	5.0V	shared with resettable fuse from front port connector
2	USB3-	I/O		
3	USB3+	I/O		
4	GND	PWR		

Table 3: USB OTG & Host Interface Connections

The signals on the internal connector doesn't have EMV filter.

The power on the 5V line is equipped with a resettable fuse with 1100mA for both front connected port and the internal port together. At 70°C the summary current is limited to 650mA.

Current consuming summary of all ports shouldn't exceed maximum power consuming limit on the 5V path.

5.3 USB Device Connector

The USB device connects the armStoneA9r2 as device on a PC.

5.4 Digital Monitor Connector

A digital monitor can be connected to the board. This interface supports up to 1080p 60Hz.

5.5 microSD Connector

The microSD push-push connector supports the SD Standard Host Specification Version 2.0 standard.

5.6 LVDS Connector

The dual channel LVDS display port can be directly connected to a LVDS 18 or 24 bit single channel or dual channel display.

By connecting 2 single channel displays to the board we recommend to use the top connector for the first channel and the second channel of the bottom connector for the second display.

LCD FI-X30P Connector				
Pin	Signal	I/O	Voltage	Remarks
1	LVDS0_DATA0-	O		shared with FI-S25P on top side
2	LVDS0_DATA0+	O		shared with FI-S25P on top side
3	LVDS0_DATA1-	O		shared with FI-S25P on top side
4	LVDS0_DATA1+	O		shared with FI-S25P on top side
5	LVDS0_DATA2-	O		shared with FI-S25P on top side
6	LVDS0_DATA2+	O		shared with FI-S25P on top side
7	GND	PWR		
8	LVDS0_CLK-	O		shared with FI-S25P on top side
9	LVDS0_CLK+	O		shared with FI-S25P on top side
10	LVDS0_DATA3-	O		shared with FI-S25P on top side
11	LVDS0_DATA3+	O		shared with FI-S25P on top side
12	LVDS1_DATA0-	O		
13	LVDS1_DATA0+	O		
14	GND	PWR		
15	LVDS1_DATA1-	O		
16	LVDS1_DATA1+	O		
17	GND	PWR		
18	LVDS1_DATA2-	O		
19	LVDS1_DATA2+	O		
20	LVDS1_CLK-	O		
21	LVDS1_CLK+	O		

22	LVDS1_DATA3-	O		
23	LVDS1_DATA3+	O		
24	GND	PWR		
25	I2C_C_DAT	I/O	3.3V	4,7kΩ Pull Up onboard
26	Backlight on	O	3.3V	High active CMOS logic
27	I2C_C_CLK	I/O	3.3V	4,7kΩ Pull Up onboard
28	I2C_RST/VLCD	O	3.3V	High active CMOS logic (Mounting option to leave open) Can be configured to VLCD on r4
29	VLCD	PWR	3.3V	Switched, max. 300mA
30	VLCD	PWR	3.3V	Switched, max. 300mA

Table 4: JILI30 dual channel LVDS connector

5.7 Backlight control connector

The connector is a Hirose 4 pin connector, model no. DF13A-4P-1.25H, mounted on the QB-lissA8 module. Pin 1 is marked on PCB.

Matching connector is a Hirose DF13-4S-1.25C with DF13-2630SCF crimping contacts.

Unused signals should be left unconnected.

Pin	Signal	I/O	Voltage	Remarks
1	VLCDON	O	3.3V	3.3V TTL level control signal; not used for backlight
2	Backlight On	O	3.3V	3.3V TTL level control signal, no power out
3	Backlight PWM	O	3.3V	3.3V TTL level control signal
4	LCD_CLK	PWR		

Table 5: Backlight control connector

5.7.1 Solution with a single cable with 3 connectors

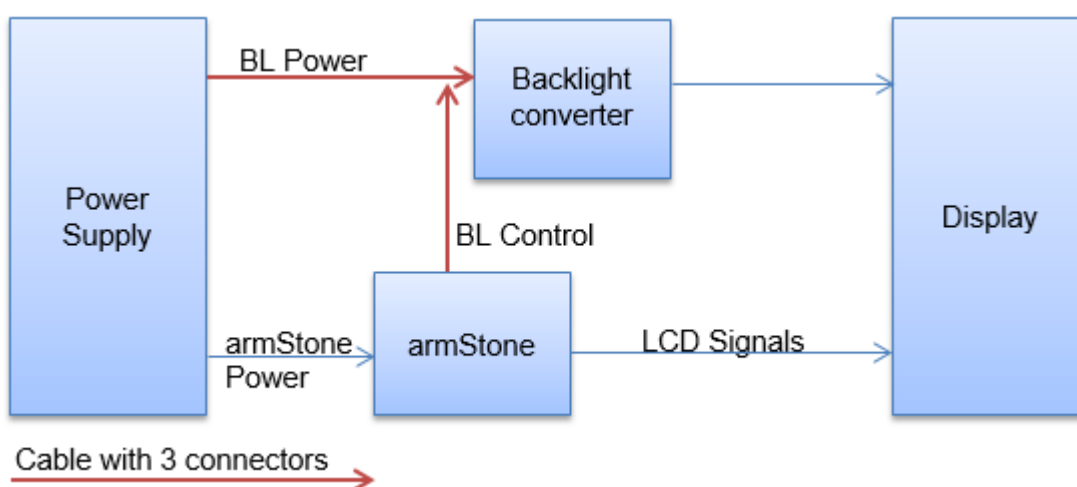

Figure 4: backlight connection with single cable

5.7.2 Solution with 2 cable with 2 connectors each

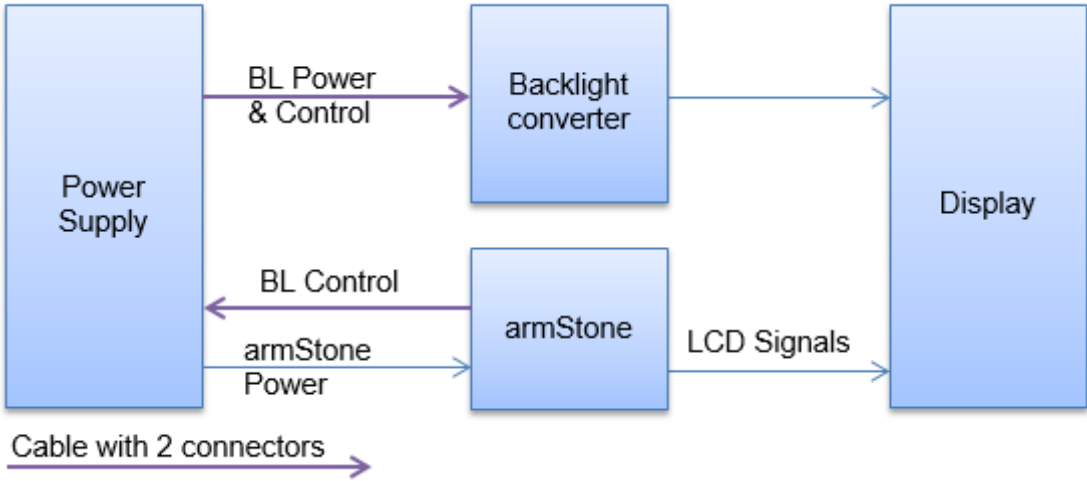

Figure 5: backlight connection with 2 cable

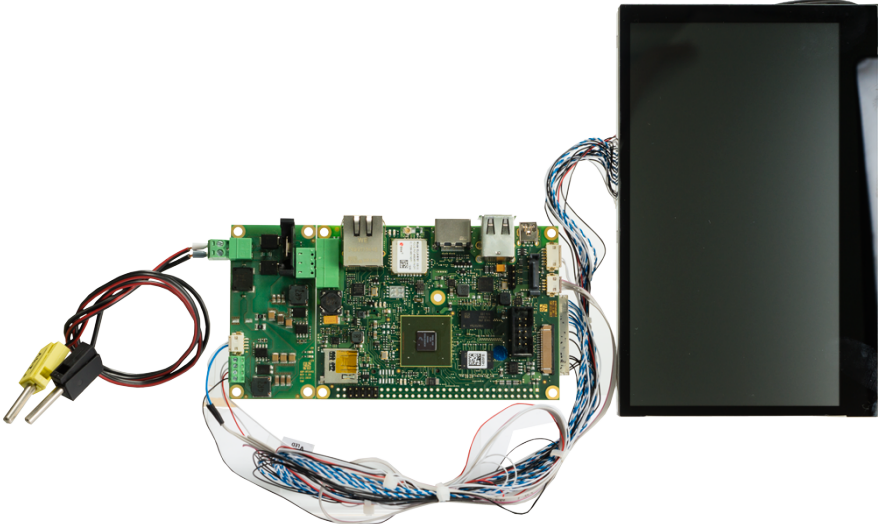

Figure 6: backlight connection with 2 cable

5.8 I2C connector for touch module

This connector is to connect the F&S SINTF-ADP-CTOUCH or SINTF-ADP-RTI2C.

The SINTF-ADP-CTOUCH module is based on Atmel mXT224 maxTouch chip working with several capacitive touch glasses.

The SINTF-ADP-RTI2C is based on Semtech SX8655 for 4 and 5 wire touch.

The connector is a Hirose 6 pin connector, model no. DF13A-6P-1.25H, mounted on the arm-StoneA9r2 module. Pin 1 is marked on PCB.

Matching connector is a Hirose DF13-6S-1.25C with DF13-2630SCF crimping contacts.

Unused signals should be left unconnected.

Pin	Signal	I/O	Voltage	Remarks
1	VCC	PWR	3.3V	
2	I2C_DAT	I/O	3.3V	
3	I2C_CLK	I/O	3.3V	
4	I2C_RST	O	3.3V	Active LOW Signal
5	I2C_IRQ	I	3.3V	Active LOW Signal
6	GND	PWR		

Table 6: I2C Touch Interface

5.9 Mini PCI Express

One 52 pin Mini-PCI-Express socket for a half-size 30x26.80 mm card is mounted on the arm-StoneA9r2. This socket does provide a PCIe channel x1 and one USB port.

5.10 CAN

This connector provides a CAN bus with transceiver. It is terminated with 120Ohm

Pin	Signal	I/O	Voltage	Remarks
1	VCC	PWR	3.3V / 5V	5V default, 3.3V mounting option
2	GND	PWR		
3	CANL	I/O		
4	CANH	I/O		
5	GND	PWR		
6	n.c.	-		
7	n.c.	-		
8	VCC	PWR	3.3V / 5V	5V default, 3.3V mounting option
9	n.c.	-		
10	n.c.	-		

5.11 Camera

This connector provides a MIPI-CSI interface with two data lanes.

Pin	Signal	I/O	Voltage	Remarks
1	GND	PWR		
2	DOM	I/O		
3	DOP	I/O		
4	GND	PWR		
5	D1M	I/O		
6	D1P	I/O		
7	GND	PWR		
8	CLK0M	I/O		
9	CLK0P	I/O		
10	GND	PWR		
11	CAM Powerdown	O	3.3V	
12	CAM Clock	O	3.3V	
13	I2C SCL	O	3.3V	
14	I2C SDA	I/O	3.3V	
15	VCC	PWR	3.3V	

5.12 WLAN (r2 only)

One of the following connector series is used for the WLAN connector:

- U.FL (Hirose)
- MHF (I-PEX/ Dai-ichi Seiko)
- AMC (Amphenol)
- IPX (Lighthouse Technologies)
- UMCC Type II/III Style A (Tyco Electronics)

The "[Letter of Conformity](#)" for this RF functionality is available from our homepage. Our pre-approval is just re-usable by using the antennas listed in this letter.

5.13 66 Pin Feature Connector

This 2.54mm connector supports CAN, RS232, Audio, ADC Input, PWM output, TTL serial ports, keyboard matrix and GPIOs.

Pin	Signal	I/O	Voltage	Remarks
1	VCC 3.3V	PWR	3.3V	
2	VCC 5.0V	PWR	5.0V	
3	XGPIO0/COL0	I/O	3.3V	
4	XGPIO1/COL1/SPI2_CLK	I/O	3.3V	
5	XGPIO2/COL2	I/O	3.3V	
6	XGPIO3/COL3/SPI2_CS _n	I/O	3.3V	
7	XGPIO4/COL4	I/O	3.3V	
8	XGPIO5/COL5/SPI2_MOSI	I/O	3.3V	
9	XGPIO6/COL6	I/O	3.3V	
10	XGPIO7/COL7/SPI2:MISO	I/O	3.3V	
11	GND	PWR		
12	XGPIO8/SPI_CLK	I/O	3.3V	
13	TX1/GPIO0	I/O	3.3V	
14	XGPIO9/SPI_CS _n	I/O	3.3V	Active LOW Signal
15	RX1/GPIO1	I/O	3.3V	
16	I2CLK/SPI_MOSI	I/O	3.3V	
17	I2DAT/SPI_MISO	I/O	3.3V	
18	XGPIO10/ROW0/TXD4	I/O	3.3V	
19	XGPIO11/ROW1/RTS2	I/O	3.3V	
20	XGPIO12/ROW2/RXD4	I/O	3.3V	
21	XGPIO13/ROW3/CTS2	I/O	3.3V	
22	XGPIO14/ROW4/RTS4	I/O	3.3V	
23	XGPIO15/ROW5/TXD3	I/O	3.3V	
24	XGPIO16/ROW6/CTS4	I/O	3.3V	
25	XGPIO17/ROW7/RXD3	I/O	3.3V	
26	XGPIO18	I/O	3.3V	
27	GND	PWR		
28	PWMOUT0	O	3.3V	
29	ADC_IN0	I	3.3V	
30	PWMOUT1	O	3.3V	
31	ADC_IN1	I	3.3V	
32	PWMOUT2	O	3.3V	
33	ADC_IN2	I	3.3V	
34	Backlight On	O	3.3V	

35	ADC_IN3	I	3.3V	
36	RXD2	I	3.3V	RS232 Signal
37	GND	PWR		
38	TXD2	O	3.3V	RS232 Signal
39	VCC 3.3V	PWR	3.3V	
40	VCC 5.0V	PWR	5.0V	
41	MIC1	I		Audio Pin 1
42	GND	PWR		
43	n.c.			
44	LINEIN_R	I		
45	LINEOUT_R	O		
46	GND	PWR		
47	GND	PWR		
48	LINEIN_L	I		
49	LINOUT_L	O		
50	GND	PWR		
51	RESETBTN	I	3.3V	
52	VCC 3.3V	PWR	3.3V	
53	n.c.	-	-	COM Pin1
54	n.v.	-	-	
55	RXD0	I	3.3V	
56	RTS0	O	3.3V	
57	TXD0	O	3.3V	
58	CTS0	I	3.3V	
59	n.c.	-	-	
60	n.c.	-	-	
61	GND	PWR		
62	VCC 5.0V	PWR	5.0V	
63	CANRX	I	3.3V	
64	CANTX	O	3.3V	
65	BOOTSEL	I	3.3V	
66	GND	PWR		

Table 7: armStone Feature Connector

On default a 9 pin connector is mounted on pin 53..61 to use a COM port standard adapter cable. *Italic signals does have a 4k7 pull-up on the module.*

5.13.1 Audio

The connector does provide Stereo Line in, Stereo Line out and microphone.

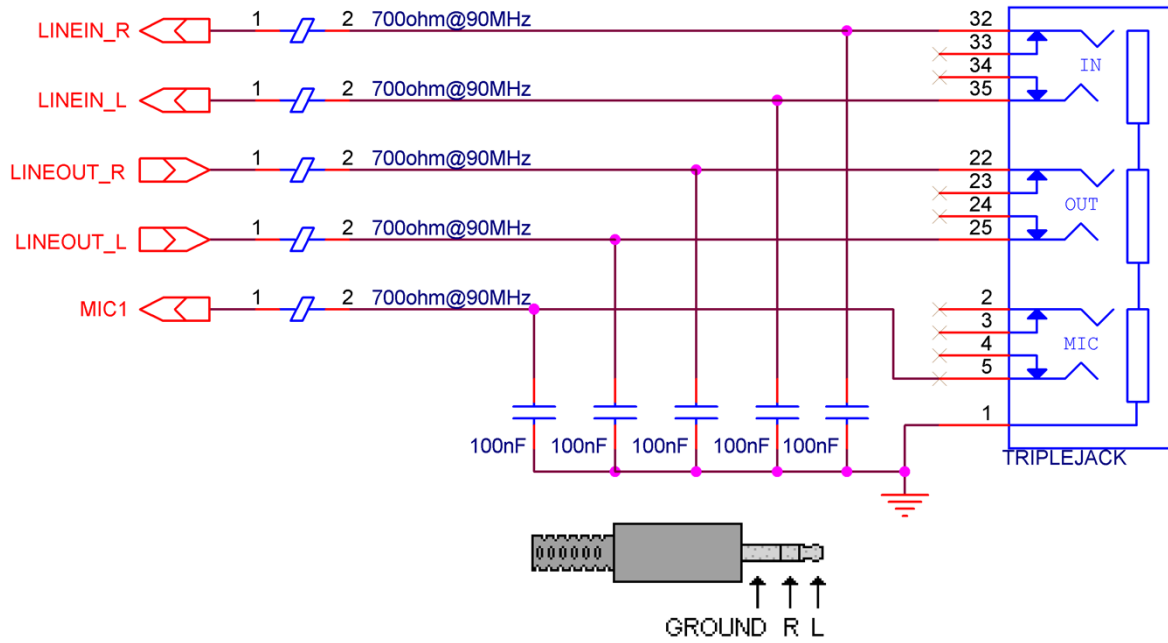

Figure 6: Audio connection

5.13.2 RS232 COM port

A 9 pin double row connector is mounted in pin 53..61. That allows attaching a standard 9pin to DSUB9 adapter cable for debug output of boot loader and kernel with TX and RX to a terminal.

An additional RX/TX COM port pair is on pin 36&38.

5.13.3 TTL COM port

There are additional serial ports with 3.3V TTL level on pins 13,15, 19 & 21, pins 23 & 25, pins 18, 20, 22 & 24.

armStoneA9r2 Feature Connector I2C Interfaces			
J1 Pin	UART2	UART3	UART4
13	TXD		
15	RXD		
18			TXD
19	RTS		
20			RXD
21	CTS		
22			RTS
23		TXD	
24			CTS
25		RXD	

5.13.4 SPI

There is a HS SPI interface available as alternative function on these pins.

Signals are 3.3V compliant and have 4.7k pull-ups on module

armStoneA9r2 Feature Connector I2C Interfaces			
Pin	Standard	Optional	Remarks
4	GPIO	SPI2_CLK	4,7kΩ PullUp onboard
6	GPIO	SPI2_CS	4,7kΩ PullUp onboard
8	GPIO	SPI2_MOSI	4,7kΩ PullUp onboard
10	GPIO	SPI2_MISO	4,7kΩ PullUp onboard
12	GPIO	SPI1_CLK	4,7kΩ PullUp onboard
14	GPIO	SPI1_CS	4,7kΩ PullUp onboard
16	GPIO	SPI1_MOSI	4,7kΩ PullUp onboard
17	GPIO	SPI1_MISO	4,7kΩ PullUp onboard

Table 8: I2C/ SPI Interfaces

5.13.5 ADC In

4 ADC inputs (ADC_IN0..3)

Created by an on board mounted [TI ADS1015](#).

This feature is just available on a custom version.

5.13.6 PWM out

3 programmable PWM outputs (PWMOUT0..2) with 3.3V level in 16.1kHz up to 33 MHz frequency range

5.13.7 Matrix keyboard

8x8 keyboard matrix (ROW0..7, COL0..1) with 3.3V level. The COL signals in pin 3..10 does have 4.7k pull-ups on board.

5.13.8 GPIOs

GPIOs are programmable as Input or Output with 3.3V TTL level. The default maximum driver current is 10mA (sink and source).

XGPIO0..9 do have 4.7k pull-up on module.

5.13.9 MISC signals, power

RESETBTN	3.3V TTL low active RESET input; use pushbutton to GND or open collector driver to pull low. Don't drive with high level.
VCC3.3, VCC5	voltage outputs for external logic, max. 100mA per pin for external chips and functions
Backlight On	3.3V TTL high active output to switch on LCD backlight. Same signal as on 4.6.1 and 4.7
Bootsel	only used for production. Don't use.

5.13.10 CAN Bus

The module does provide the CAN bus transmit and receive TTL signal without any termination in standard version (CANRX, CANTX). Both signals are working with 3.3V level.

Needs a interface chip to the CAN bus showing below. If not used, please left signals unconnected.

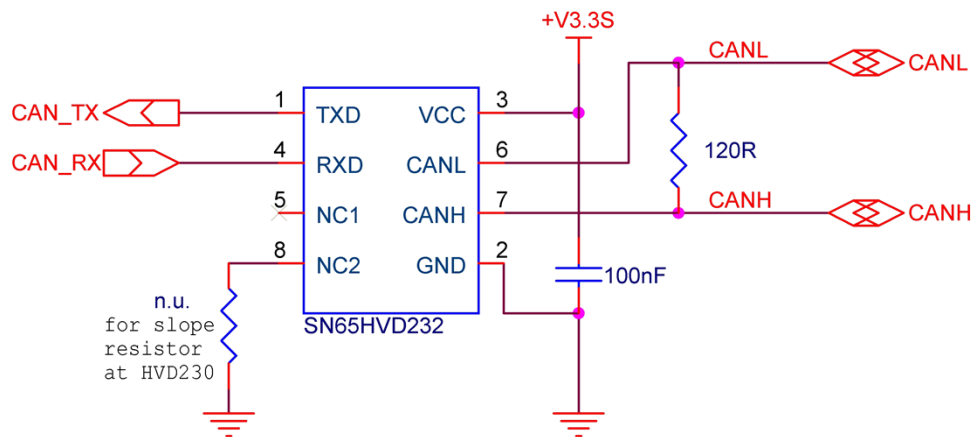

Figure 7: CAN transceiver circuit

5.14 Power connector

A 5 pin power connector is mounted on the module.

Connector type

- [Phoenix contact](#) MC 1,5/ 5-G-3,81 1803303
- [Würth Elektronik](#) order no. 691 322 310 005

For matching connectors please refer the connector manufacturer website.

Pin	Signal	I/O	Voltage	Remarks
1	n.c.	-	-	
2	RTC Battery	PWR		for RTC battery, don't connect if not used
3	VCC IN	PWR	5.0V	
4	GND IN	PWR		
5	VCC OUT	PWR	3.3V	Power output for external logic, max. current 50mA

Table 9: Power Connector

If an external 3.3V power supply is used for external logic, we recommend to use the “VCC Out 3.3V” as enable signal for this power supply to avoid backdrive leak current thru IO pins.

6 Electrical characteristic

6.1 Absolute maximum ratings

Description	Min	Max	Unit
Input Voltage range 3.3V IO pins	-0.3	OVDD*+0.3	V
Voltage on any IO with VIN off		0.3	V
USB VBUS	-0.3	5.6	V
Maximum power consumption VDD_VBAT at 25°C		10	μA
Maximum output current VLCD		300	mA
Thermal design power (summary all chips) (with 1GHz Quad CPU)*		11.5	W
Thermal design power (summary all chips) (with 1GHz DualLite CPU)*		7	W
Thermal design power (summary all chips) (with 1GHz Solo CPU)*		6	W

Table 10: Absolute Maximum Ratings

* Power consumption of connected devices like display, USB devices, SD card, miniPCle card has to be added for power calculation.

6.2 DC Electrical Characteristics

Parameter	Description	Condition	Min	Max	Unit
VIN	Module main power		4.7	5.5	V
VBAT	RTC power		0.9	5.5	V
USB_OTG*_VBUS	USB supply voltage		4.4	5.5	
OVDD	On module 3.3V DCDC		3.15	3.45	V
V _{ih}	High Level Input Voltage		0.7*OVDD	OVDD	V
V _{il}	Low Level Input Voltage		0	0.3*OVDD	V
V _{oh}	High Level Output Voltage	I _{oh} =0.1mA	OVDD-0,15		V
V _{ol}	Low Level Output Voltage	I _{ol} =0.1mA		0.15	V
I _o	Output current IOs	3.3V		5	mA

OVDD = power on pin 3.3V from on module DCDC

Table 11: DC Electrical Characteristics

7 Thermal Specification

Description	Min	Typ	Max	Unit
Operating temperature i.MX6 ("C-Temp")	0		+70 ¹	°C
Operating temperature i.MX6 ("I-Temp") ²	-20		+85 ¹	°C
Junction temperature i.MX6 ("C-Temp")	-20		+105	°C
Junction temperature i.MX6 ("I-Temp") ²	-20		+105	°C
Junction to Package Top of i.MX6 (Psi-JT) ³		2		°C/W

¹ Depending on cooling solution. See also: [Power consumption and cooling](#)

² Optional

³ Temperature difference between package top and the junction temperature per JEDEC JESD51-2.

8 ADP-NT24V2

To power the armStoneA9r2 with 7,5-36V F&S provide ADP-NT24V2:

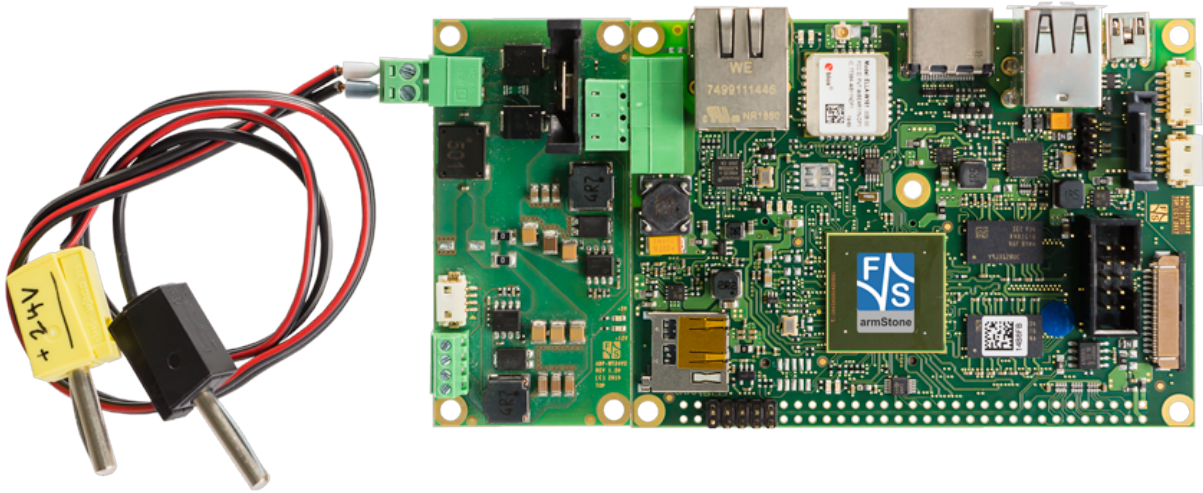

The extension board is designed to plug it into the power Connector of the armStone.

For more information check the F&S website:

<https://www.fs-net.de/de/produkte/zubehoer/power-adapter-2/>

9 Review service

F&S provide a schematic review service for your baseboard implementation. Please send your schematic as searchable PDF to support@fs-net.de.

10 Second source rules

F&S qualifies their second sources for parts autonomously, as long as this does not touch the technical characteristics of the product. This is necessary to guarantee delivery times and product life. A setup of release samples with released second sources is not possible.

F&S does not use broker components without the consent of the customer.

11 Power consumption and cooling

Depend you product version you will have different temperature range and power consumption of the module.

The operating temperature can be measured on the mounting holes on top of the module and **shouldn't exceed the maximum operating temperature of the board (85°C)**.

The maximum power consumption of the board could be 11.5 Watt. This value is with 100% working of cores and full working graphic engines. Calculating with this scenario does need an expensive cooling.

Depend your application and your worst case scenario the maximum power consumption is much lower. This will save money on your cooling solution. We recommend to measure this with your application. We see values between max. **5** and **11.5** Watt on different custom applications.

Because the different environments for air temperature, airflow, thermal radiation, power consumption of the board on your application and the power consumption of other components like power supply and LCD inside the system you have to calculate a working cooling solution for the board.

Just cooling the CPU with 70-90% of the power consumption of the entire board is the best way to cool the board.

To calculate your cooling we recommend this helpful literature and the CPU datasheet

- [AN4579 from NXP: Thermal management guidelines](#)
- [fischerelektronik.de/web_fisch...eKataloge/Heatsinks/#/18/](http://www.fischerelektronik.de/web_fisch...eKataloge/Heatsinks/#/18/)
- http://www.eetimes.com/document.asp?doc_id=1276748
- http://www.eetimes.com/document.asp?doc_id=1276750

12 Storage conditions

Maximum storage on room temperature with non-condensing humidity: 6 months

Maximum storage on controlled conditions 25 ±5 °C, max. 60% humidity: 12 months

For longer storage we recommend vacuum dry packs.

13 ROHS and REACH statement

All F&S designs are created from lead-free components and are completely ROHS compliant.

The products we supply do not contain any substance on the latest candidate list published by the European Chemicals Agency according to Article 59(1,10) of Regulation (EC) 1907/2006 (REACH) in a concentration above 0.1 mass %.

Consequently, the obligations in No. 1 and 2 paragraphs in Annex are not relevant here.

Please understand that F&S is not performing any chemical analysis on its products to testify REACH compliance and is therefore not able to fill out any detailed inquiry forms.



14 Packaging

All F&S ESD-sensitive products are shipped either in trays or bags.

The modules are shipped in trays. One tray can hold 20 boards. An empty tray is used as top cover.

15 Matrix Code Sticker

All F&S hardware is shipped with a matrix code sticker including the serial number. Enter your serial number here <https://www.fs-net.de/en/support/serial-number-info-and-rma/> to get information on shipping date and type of board.



Figure 4: Matrix Code Sticker

16 Appendix

Important Notice

The information in this publication has been carefully checked and is believed to be entirely accurate at the time of publication. F&S Elektronik Systeme (“F&S”) assumes no responsibility, however, for possible errors or omissions, or for any consequences resulting from the use of the information contained in this documentation.

F&S reserves the right to make changes in its products or product specifications or product documentation with the intent to improve function or design at any time and without notice and is not required to update this documentation to reflect such changes.

F&S makes no warranty or guarantee regarding the suitability of its products for any particular purpose, nor does F&S assume any liability arising out of the documentation or use of any product and specifically disclaims any and all liability, including without limitation any consequential or incidental damages.

Specific testing of all parameters of each device is not necessarily performed unless required by law or regulation.

Products are not designed, intended, or authorized for use as components in systems intended for applications intended to support or sustain life, or for any other application in which the failure of the product from F&S could create a situation where personal injury or death may occur. Should the Buyer purchase or use a F&S product for any such unintended or unauthorized application, the Buyer shall indemnify and hold F&S and its officers, employees, subsidiaries, affiliates, and distributors harmless against all claims, costs, damages, expenses, and reasonable attorney fees arising out of, either directly or indirectly, any claim of personal injury or death that may be associated with such unintended or unauthorized use, even if such claim alleges that F&S was negligent regarding the design or manufacture of said product.

Specifications are subject to change without notice.

Warranty Terms

Hardware Warranties

F&S guarantees hardware products against defects in workmanship and material for a period of one (1) year from the date of shipment. Your sole remedy and F&S's sole liability shall be for F&S, at its sole discretion, to either repair or replace the defective hardware product at no charge or to refund the purchase price. Shipment costs in both directions are the responsibility of the customer. This warranty is void if the hardware product has been altered or damaged by accident, misuse or abuse.

Software Warranties

Software is provided "AS IS". F&S makes no warranties, either express or implied, with regard to the software object code or software source code either or with respect to any third party materials or intellectual property obtained from third parties. F&S makes no warranty that the software is useable or fit for any particular purpose. This warranty replaces all other warranties written or unwritten. F&S expressly disclaims any such warranties. In no case shall F&S be liable for any consequential damages.

Disclaimer of Warranty

THIS WARRANTY IS MADE IN PLACE OF ANY OTHER WARRANTY, WHETHER EXPRESSED, OR IMPLIED, OF MERCHANTABILITY, FITNESS FOR A SPECIFIC PURPOSE, NON-INFRINGEMENT OR THEIR EQUIVALENTS UNDER THE LAWS OF ANY JURISDICTION, EXCEPT THE WARRANTY EXPRESSLY STATED HEREIN. THE REMEDIES SET FORTH HEREIN SHALL BE THE SOLE AND EXCLUSIVE REMEDIES OF ANY PURCHASER WITH RESPECT TO ANY DEFECTIVE PRODUCT.

Limitation on Liability

UNDER NO CIRCUMSTANCES SHALL F&S BE LIABLE FOR ANY LOSS, DAMAGE OR EXPENSE SUFFERED OR INCURRED WITH RESPECT TO ANY DEFECTIVE PRODUCT. IN NO EVENT SHALL F&S BE LIABLE FOR ANY INCIDENTAL OR CONSEQUENTIAL DAMAGES THAT YOU MAY SUFFER DIRECTLY OR INDIRECTLY FROM USE OF ANY PRODUCT. BY ORDERING THE PRODUCT, THE CUSTOMER APPROVES THAT THE F&S PRODUCT, HARDWARE AND SOFTWARE, WAS THOROUGHLY TESTED AND HAS MET THE CUSTOMER'S REQUIREMENTS AND SPECIFICATIONS



17 Content

Table 1: Mechanical Dimensions.....	6
Table 2: Thermal Specification	8
Table 3: USB OTG & Host Interface Connections.....	9
Table 4: JILI30 dual channel LVDS connector	11
Table 5: Backlight control connector.....	11
Table 6: I2C Touch Interface	13
Table 7: armStone Feature Connector	16
Table 8: I2C/ SPI Interfaces.....	19
Table 9: Power Connector	21
Table 10: Absolute Maximum Ratings	22
Table 11: DC Electrical Characteristics	22
Figure 1: Block Diagram	5
Figure 2: Mechanical Dimension	6
Figure 3: Connector Layout	9
Figure 4: Matrix Code Sticker	26