

Hardware Documentation

LCD.10.LVDS.1

*10" LVDS Display (1024x600px)
with capacitive touch sensor*

preliminary

Version 001
(2024-05-08)



**Elektronik
Systeme**

© F&S Elektronik Systeme GmbH

Untere Waldplätze 23

D-70569 Stuttgart

Phone: +49(0)711-123722-0

Fax: +49(0)711-123722-99

About This Document

This document describes how to use the **LCD.10.LVDS.1** display with mechanical and electrical information. The latest version of this document can be found at: <http://www.fs-net.de>.

ESD Requirements



All F&S hardware products are ESD (electrostatic sensitive devices). All products are handled and packaged according to ESD guidelines. Please do not handle or store ESD-sensitive material in ESD-unsafe environments. Negligent handling will harm the product and warranty claims become void.

History

Date	V	Platform	A,M,R	Chapter	Description	Au
17.05.24	001	All			Initial Version	SM

V Version
A, M, R Added, Modified, Removed
Au Author

Table of Contents

About This Document	2
ESD Requirements	2
History	2
Table of Contents	3
1 Overview	4
1.1 Mechanic	4
1.2 Connectors	5
2 Electrical Characteristics	6
2.1 Recommended Operating Conditions	6
2.2 Absolute Maximum Ratings	6
3 Detailed Description	7
3.1 LVDS & I ² C In Connector	7
3.2 Backlight Supply	8
3.3 Control Signals	8
3.4 Display Configurations	9
3.5 VCOM	9
3.6 Software	9
4 ESD and EMI Implementation	10
5 Second source rules	10
6 Storage conditions	10
7 ROHS and REACH statement	10
8 Packaging	10
9 Matrix Code Sticker	10
10 Appendix	11
Important Notice	11
Warranty Terms	12
11 Content	13

1 Overview

The LCD.10.LVDS.1 is a LCD display with capacitive touch including an adapter for the display and backlight voltages and an I2C IO expander for control signals.

1.1 Mechanic

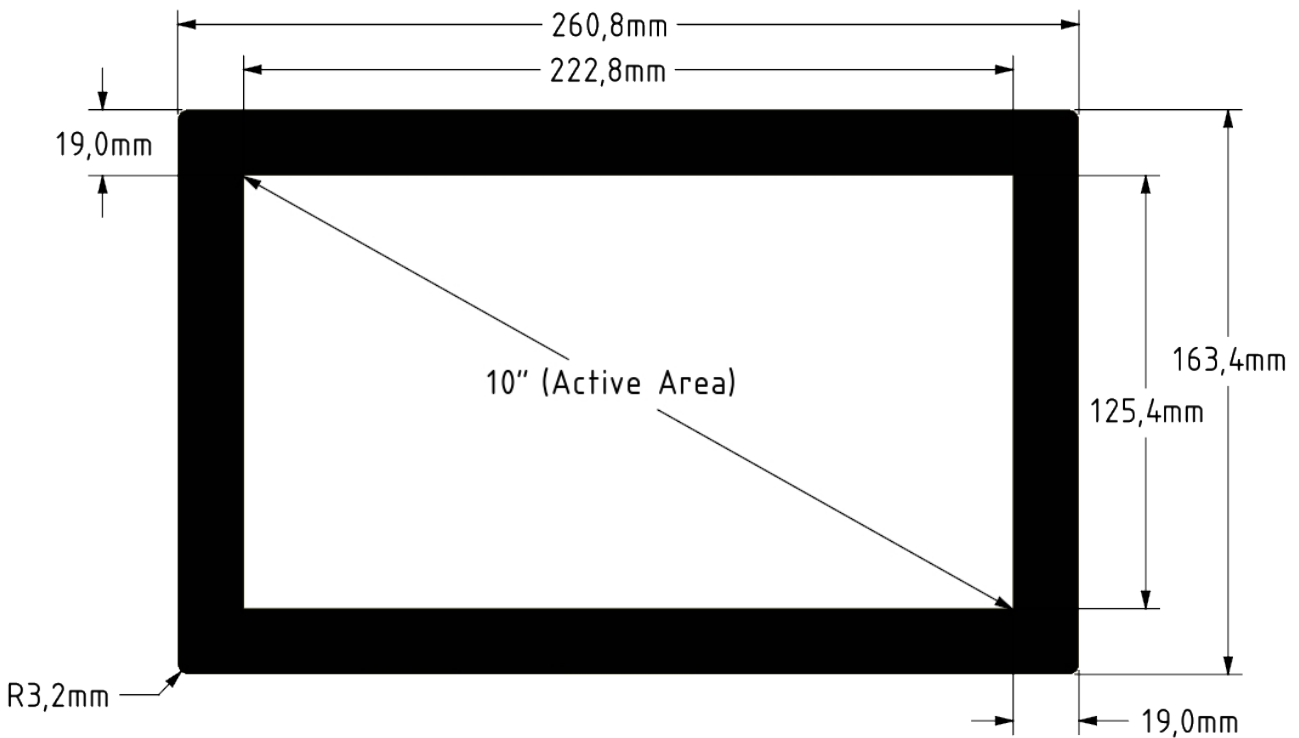
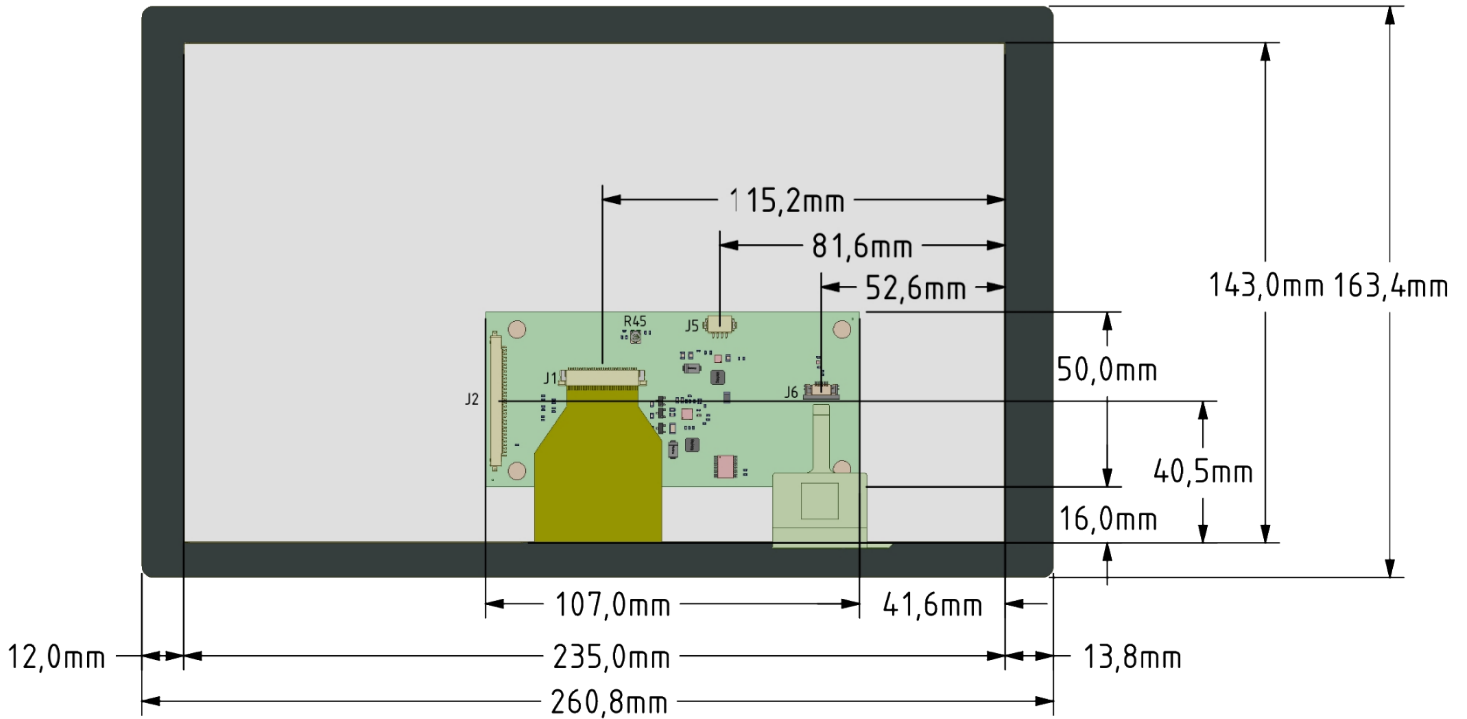

Dimensions	Description
Display Thickness	5.2 mm (10.8 mm with Adapter)
Weight	465g ±10g
Tolerance	±0.2 mm
Operating Temperature	-20 ... +70°C
Resolution	1024 x 600 Pixel (RGB)
Active Area	222.8 x 125.4 mm
Surface Luminance	Typ. 425 cd/m ²
Cover Material	Glass

Table 1: General dimensions

1.2 Connectors

Ref.	Description	Connector Type
J1	Display	FPC 40pol, Pitch: 0.50mm TE, 4-1734839-0
J2	LVDS & I ² C In	FPC 30pol, Pitch: 1.00mm Hirose, MDF76GW-30S-1H(55)
J5	Backlight Supply 5V	Header 4pol, Pitch: 1.25mm Hirose, DF13-4P-1.25H(20)
J6	Touch	FPC 8pol, Pitch: 0.50mm TE, 1734592-8

Table 2: Connector list

2 Electrical Characteristics

2.1 Recommended Operating Conditions

Parameter	Description	Min.	Typ.	Max.	Unit
V_{IN}	Input voltage for the display at J2	3.00		3.30	V
P_{IN}	Power consumption Display, Touch & I ² C IO Expander at 3,3V		0.65		W
$V_{BL IN}$	Input voltage for the Backlight at J5	3.30 ¹	5.0	10.20	V
$P_{BL IN}$	Power consumption Backlight at 5V and PWM frequency at:		0.60 1.30 2.50		W
$V_{I2C LOW}$	I ² C SDA/SCL LOW-level input voltage	-0.30		+0.25V _{IN}	V
$V_{I2C HIGH}$	I ² C SDA/SCL HIGH-level input voltage	0.75V _{IN}		V _{IN} +0.30	V

¹For the full brightness a minimum of 5V is needed.

Table 3: Recommended operation conditions

2.2 Absolute Maximum Ratings

Parameter	Description	Min.	Max.	Unit
V_{IN}	Input voltage for the Display at J2	1.80	3.47	V
$V_{BL IN}$	Input voltage for the Backlight at J5	0.00	10.20	V

Table 4: Absolute maximum ratings

3.2 Backlight Supply

The display uses a LED Backlight with the following electrical characteristics.

Parameter	Description	Min.	Typ.	Max.	Unit
I_F	Forward current backlight LED		0.26		A
V_F	Forward voltage backlight LED	8.10		9.90	V
t_{DUR}	Durability until 50% of initial brightness	30000.00 ¹			h

¹ If the backlight is driven under high current, high ambient temperature and humidity conditions, the lifetime will be reduced.

Table 6: Electrical characteristics of the backlight

Pin	Signal Name	Description
1	$V_{BL IN}$	Supply input for backlight
2		
3	GND	Ground
4		

Table 7: Connector Pinout J5

A suitable cable can be purchased by F&S under the Part No.: B.MKAB.35

Note: Optional the backlight can be supplied by the LVDS & I²C In connector with a voltage of 3,3V and a max current of 100mA. For this option hardware modifications are needed.

3.3 Control Signals

An I²C IO expander is used to generate control signals for display, touch sensor and backlight. The used expander is a NXP PCA9634PW. The I²C Adress of the expander is 0x61. All pins must be configured as open drain. The PWM signal for the backlight brightness uses the group duty cycle register 0x0A of the chip, because of the lower frequency. Please see the datasheet of the chip for further information.

Pin	Signal Name	Description
6	BL ON	Turns the backlight on and off.
7	BL PWM	Control signal for brightness.
9	DISPLAY RESET	Reset signal for the display.
12	TOUCH RESET	Reset signal for the touch sensor.

Table 8: Pin and signal list IO expander

3.4 Display Configurations

The display can be configured with pull up and down resistors. The resistors are placed below the display FPC connector.



Figure 3: Config resistors position

Ref	Signal Name	Level	Description
R1	Standby Mode	HIGH	Normal operation
R6		LOW	Timing controller source driver will turn off, all outputs are HIGH-Z
R7	SELB	HIGH	6bit Mode
R13		LOW	8bit Mode
R8	Left/Right	HIGH	Left to right scan direction
R14		LOW	Right to left scan direction
R9	Up/Down	HIGH	Bottom to top scan direction
R15		LOW	Top to Bottom scan direction

Table 9: Display configurations

3.5 VCOM

R45 is used to set the VCOM voltage (Pixel reference voltage). It can be adjusted from 3.6V to 4.2V.

3.6 Software

Drivers for the F&S boards with an LVDS Interface are provided.

4 ESD and EMI Implementation

The connectors do not have any protection. We highly recommend using the adapter board with wires as short as possible.

A helpful guide is available from TI; just search for slva680 at ti.com.

5 Second source rules

F&S qualifies their second sources for parts autonomously, as long as this does not touch the technical characteristics of the product. This is necessary to guarantee delivery times and product life. A setup of release samples with released second sources is not possible.

F&S does not use broker components without the consent of the customer.

6 Storage conditions

Maximum storage on room temperature with non-condensing humidity: 6 months

Maximum storage on controlled conditions 25 ±5 °C, max. 60% humidity: 1 2 months

For longer storage, we recommend vacuum dry packs.

7 ROHS and REACH statement

All F&S designs are created from lead-free components and are completely ROHS compliant.

The products we supply do not contain any substance on the latest candidate list published by the European Chemicals Agency according to Article 59(1,10) of Regulation (EC) 1907/2006 (REACH) in a concentration above 0.1 mass %.

Consequently, the obligations in No. 1 and 2 paragraphs in Annex are not relevant here.

Please understand that F&S is not performing any chemical analysis on its products to testify REACH compliance and is therefore not able to fill out any detailed inquiry forms.

8 Packaging

All F&S ESD-sensitive products will shipping either in trays or in bags.

9 Matrix Code Sticker

All F&S hardware will ship with a matrix code sticker including the serial number. Enter your serial number here <https://www.fs-net.de/en/support/serial-number-info-and-rma/> to get information on shipping date and type of board.



Figure 2: Matrix Code Sticker

10 Appendix

Important Notice

The information in this publication has been carefully checked and is believed to be entirely accurate at the time of publication. F&S Elektronik Systeme (“F&S”) assumes no responsibility, however, for possible errors or omissions, or for any consequences resulting from the use of the information contained in this documentation.

F&S reserves the right to make changes in its products or product specifications or product documentation with the intent to improve function or design at any time and without notice and is not required to update this documentation to reflect such changes.

F&S makes no warranty or guarantee regarding the suitability of its products for any particular purpose, nor does F&S assume any liability arising out of the documentation or use of any product and specifically disclaims any and all liability, including without limitation any consequential or incidental damages.

Specific testing of all parameters of each device is not necessarily performed unless required by law or regulation.

Products are not designed, intended, or authorized for use as components in systems intended for applications intended to support or sustain life, or for any other application in which the failure of the product from F&S could create a situation where personal injury or death may occur. Should the Buyer purchase or use a F&S product for any such unintended or unauthorized application, the Buyer shall indemnify and hold F&S and its officers, employees, subsidiaries, affiliates, and distributors harmless against all claims, costs, damages, expenses, and reasonable attorney fees arising out of, either directly or indirectly, any claim of personal injury or death that may be associated with such unintended or unauthorized use, even if such claim alleges that F&S was negligent regarding the design or manufacture of said product.

Specifications are subject to change without notice.

Warranty Terms

Hardware Warranties

F&S guarantees hardware products against defects in workmanship and material for a period of one (1) year from the date of shipment. Your sole remedy and F&S's sole liability shall be for F&S, at its sole discretion, to either repair or replace the defective hardware product at no charge or to refund the purchase price. Shipment costs in both directions are the responsibility of the customer. This warranty is void if the hardware product has been altered or damaged by accident, misuse or abuse.

Software Warranties

Software is provided "AS IS". F&S makes no warranties, either express or implied, with regard to the software object code or software source code either or with respect to any third party materials or intellectual property obtained from third parties. F&S makes no warranty that the software is useable or fit for any particular purpose. This warranty replaces all other warranties written or unwritten. F&S expressly disclaims any such warranties. In no case shall F&S be liable for any consequential damages.

Disclaimer of Warranty

THIS WARRANTY IS MADE IN PLACE OF ANY OTHER WARRANTY, WHETHER EXPRESSED, OR IMPLIED, OF MERCHANTABILITY, FITNESS FOR A SPECIFIC PURPOSE, NON-INFRINGEMENT OR THEIR EQUIVALENTS UNDER THE LAWS OF ANY JURISDICTION, EXCEPT THE WARRANTY EXPRESSLY STATED HEREIN. THE REMEDIES SET FORTH HEREIN SHALL BE THE SOLE AND EXCLUSIVE REMEDIES OF ANY PURCHASER WITH RESPECT TO ANY DEFECTIVE PRODUCT.

Limitation on Liability

UNDER NO CIRCUMSTANCES SHALL F&S BE LIABLE FOR ANY LOSS, DAMAGE OR EXPENSE SUFFERED OR INCURRED WITH RESPECT TO ANY DEFECTIVE PRODUCT. IN NO EVENT SHALL F&S BE LIABLE FOR ANY INCIDENTAL OR CONSEQUENTIAL DAMAGES THAT YOU MAY SUFFER DIRECTLY OR INDIRECTLY FROM USE OF ANY PRODUCT. BY ORDERING THE PRODUCT, THE CUSTOMER APPROVES THAT THE F&S PRODUCT, HARDWARE AND SOFTWARE, WAS THOROUGHLY TESTED AND HAS MET THE CUSTOMER'S REQUIREMENTS AND SPECIFICATIONS

11 Content

Table 1: General dimensions.....	5
Table 2: Connector list.....	5
Table 3: Recommended operation conditions	6
Table 4: Absolute maximum ratings	6
Table 5: Connector Pinout J2	7
Table 6: Electrical characteristics of the backlight.....	8
Table 7: Connector Pinout J5	8
Table 8: Pin and signal list IO expander	8
Table 9: Display configurations.....	9
Figure 1: Back view, all dimensions in mm.....	4
Figure 2: Top view, all dimensions in mm.....	4
Figure 3: Config resistors position	9